



PodFactory + Arch leisure

Luxury Lodges

Quotation valid for 30 days

Glamping pod specification 10/4m 1 bed lodge

Construction Spec	Info
Walls	100/50mm Treated timbers. 85mm celotex insulation
Roof	150/50mm Treated timbers 85mm celotex insulation
Floor	100/50mm Treated timbers. 85mm celotex insulation
Added insulation	Multi foil insulation. 60mm
External specification	
Chassis spec	Heavy duty chassis. Large 200/100/5mm Main members with 125/60mm Outriggers.
External cladding	Canaxel Cladding
External Roof covering	-Metrotile Bond tile.
Internal Specification	
Kitchen	High quality Howdens kitchen . Mirostone worktops. Fridge, dishwasher, oven and Hob.
Bathrooms	1 x 1200/800mm bespoke vanity unit, standard toilet.
Internal boards	MDF internal cladding. V groove cladding 125/12mm
Internal flooring	LVL flooring (colour TBC)
Windows and doors	UPVC Windows and doors. 1 x 3500mm Sliding door, 1 x 1200/800mm opening window.
Internal doors	Holdenby Oak internal doors. Finished with OSMO treatment.
Electrical	
Sockets and switches	All electrics installed to 18th edition. Brushed stainless switches and sockets with USB by the beds.
Lighting	All internal lighting warm white spot lights and external LED lighting.
Plumbing	
	All plumbing installed and tested by gas safe engineer. All heat loss calculations will be supplied. All pipe work to be N pressed fittings.
Base Price:	£52,500.00
Wheeled Chassis	£550.00
LPG	£850.00
Total price	£53,900.00
Furniture	£5,750.00
Delivery estimate:	£3,950.00

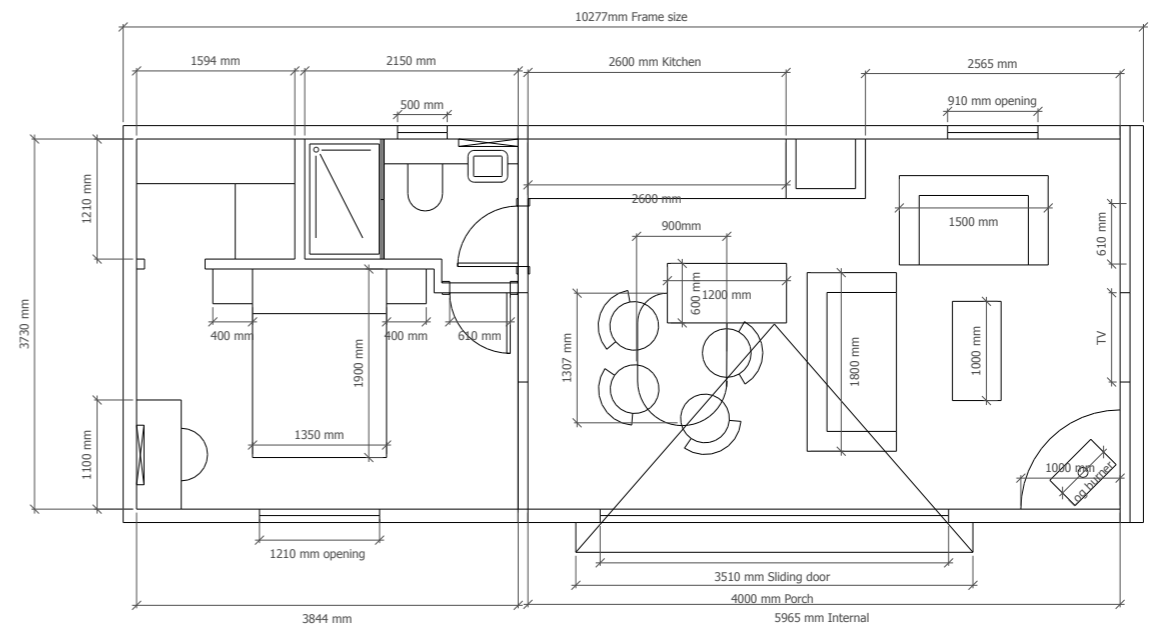

***Price excludes the base and the connections on site, Payments are 50% upfront, 50% upon completion before delivery is arranged. Sizes on the plan may vary slightly during the build. Delivery requires Telehandler for the unloading and moving of the buildings. Furniture excluded**

Glamping pod specification 10/4m 1 bed lodge

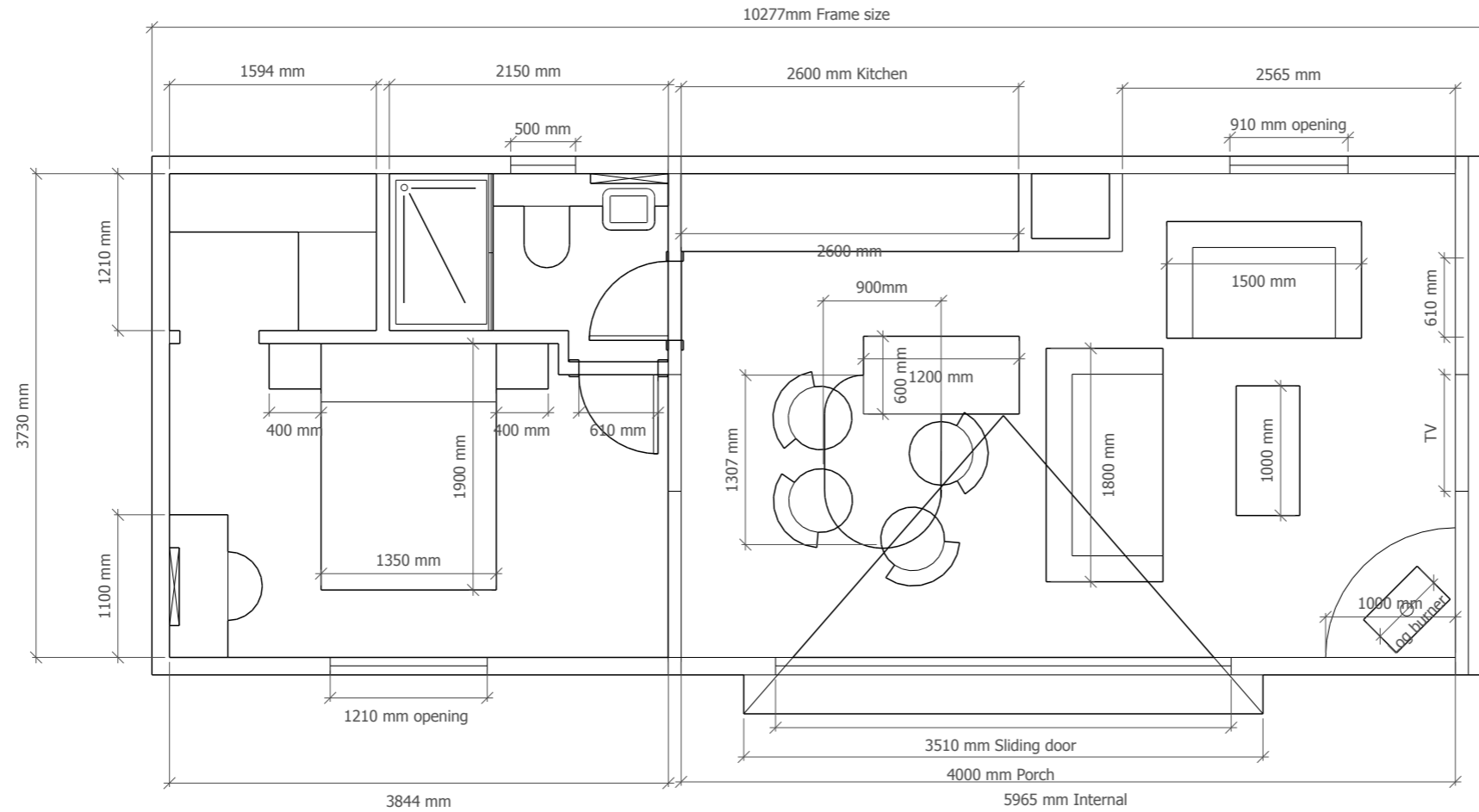

Example layout, layout and sizes may vary depending on Lodge and spec *

Glamping pod layout 14/4m 2 Bed lodge

Construction Spec	Info
Walls	100/50mm Treated timbers. 85mm celotex insulation
Roof	150/50mm Treated timbers 85mm celotex insulation
Floor	100/50mm Treated timbers. 85mm celotex insulation
Added insulation	Multi foil insulation. 60mm
External specification	
Chassis spec	Heavy duty chassis. Large 200/100/5mm Main members with 125/60mm Outriggers.
External cladding	Canaxel Cladding
External Roof covering	-Metrotile Bond tile.
Internal Specification	
Kitchen	High quality Howdens kitchen . Mirostone worktops. Fridge, dishwasher, oven and Hob.
Bathrooms	2 x 1200/800mm, bespoke vanity unit, standard toilet.
Internal boards	MDF internal cladding. V groove cladding 125/12mm
Internal flooring	LVL flooring (colour TBC)
Windows and doors	UPVC Windows and doors. 1 x 3500mm Sliding door, 2 x 1200/800mm opening window, 500/900mm window x 2, 900/450mm.
Internal doors	Holdenby Oak internal doors. Finished with OSMO treatment.
Electrical	
Sockets and switches	All electrics installed to 18th edition. Brushed stainless switches and sockets with USB by the beds.
Lighting	All internal lighting warm white spot lights and external LED lighting.
Plumbing	
All plumbing installed and tested by gas safe engineer. All heat loss calculations will be supplied. All pipe work to be N pressed fittings.	
Base Price:	£60,900.00
Wheeled Chassis	£550.00
LPG	£850.00
Total price	£62,300.00
Furniture	£6,950.00
Delivery estimate:	£3,950.00

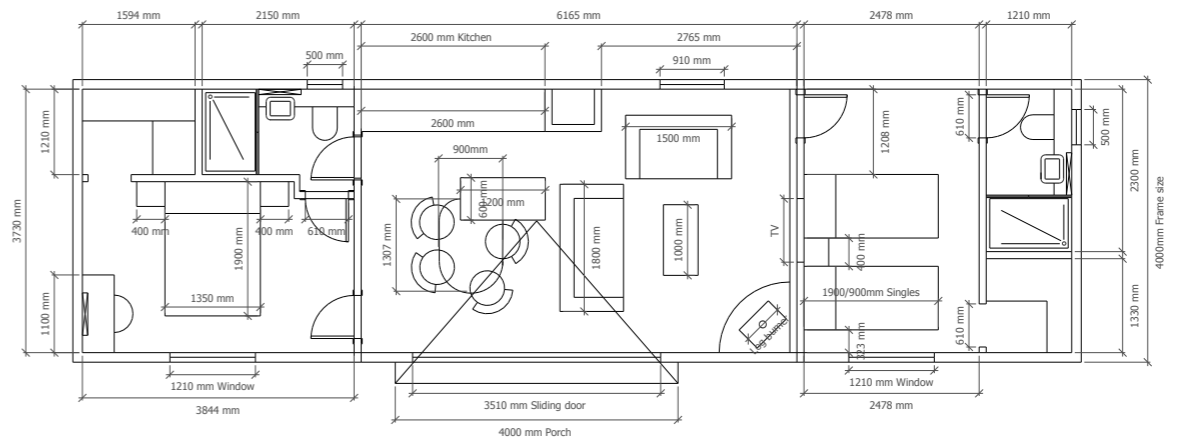

***Price excludes the base and the connections on site, Payments are 50% upfront, 50% upon completion before delivery is arranged. Sizes on the plan may vary slightly during the build. Delivery requires Telehandler for the unloading and moving of the buildings. Furniture excluded**

Glamping pod layout 14/4m 2 Bed lodge

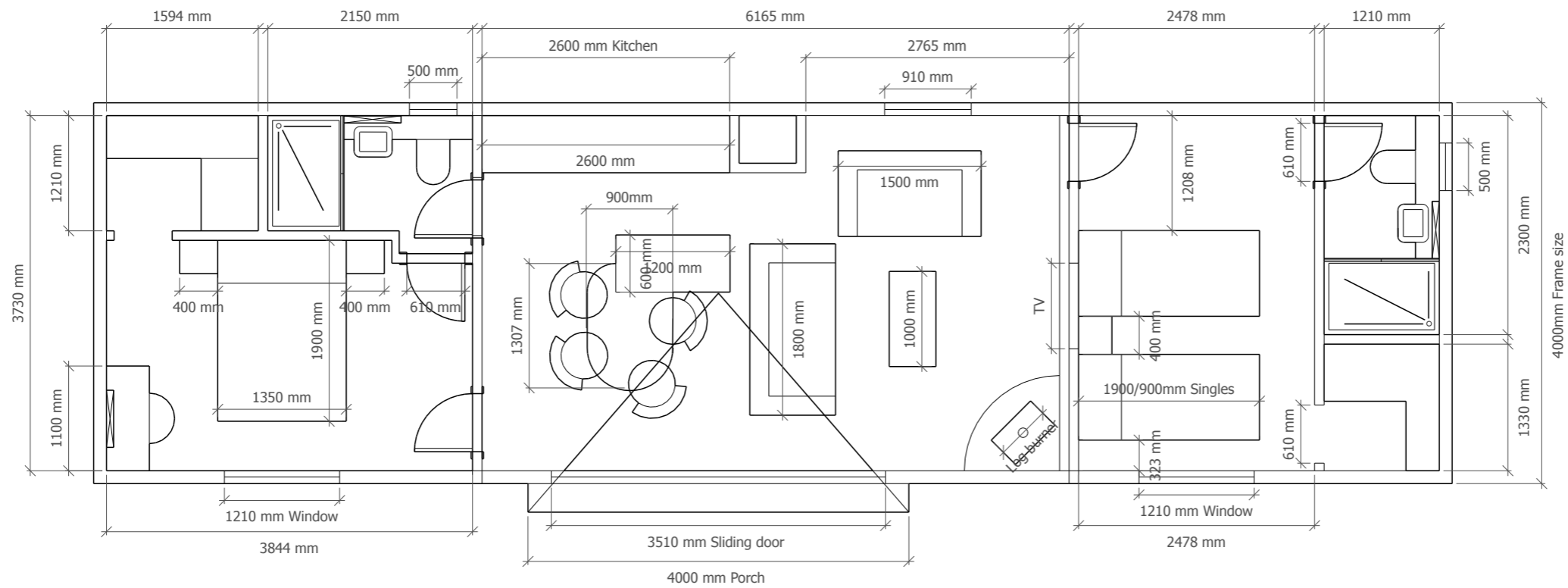

Example layout, layout and sizes may vary depending on Pod and spec *



PodFactory + Arch leisure

Luxury Lodges

Quotation valid for 30 days